

STEEL INSERT SYSTEM®
Pergola Parts List



Post Adapter



Rail Adapter



Rail Connector

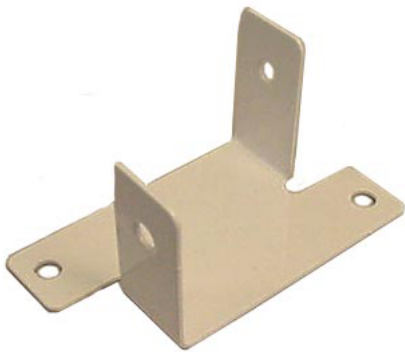

Powder Coated Steel
Stringer Bracket



Stainless Steel
Powder Coated
Screw



Pergola Caps

STRUCTURAL PERGOLAS

Featuring the *STEEL INSERT SYSTEM* ®

Important information:

1. Placement of post holes.
2. Height of bottom beam.

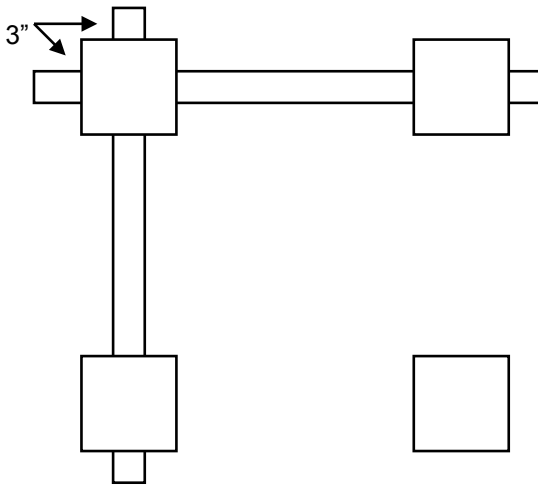

- 1. At least 3" of beam must protrude from posts** (before cap is added). *For example:* If beam is 16' long, vinyl posts can be a **maximum** of 15'6" outside to outside. If it is shorter, beam can be trimmed. Post placement is critical to achieve structural integrity. *These measurements may be adjusted.* For best results, lay out footprint to ensure material fits correctly. **Read instructions thoroughly so important steps will not be omitted.**

Beams must be filled with aluminum or steel to maintain metal to metal connection.

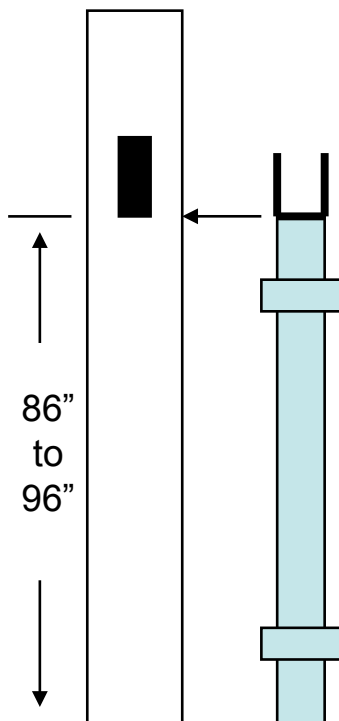

- 2. Determine the height of your bottom beam** (generally between 86" and 96"). The steel posts must be installed so the top of steel post is level with the bottom hole on the vinyl post. The Rail Adapter inserts into steel post, then the **filled rail must slide through the vinyl post, resting on the post adapter.** The steel posts can be set higher and cut to fit if necessary. **3" or 4" 40wt galvanized pipe is recommended.**

- 3. Following steps 1&2 will ensure your pergola is structural and the material will fit correctly.**

Determine post placement, dig holes (at least 3' deep) and set in concrete, or core drill into concrete pad (8" -12" recommended) and set with hydraulic cement, following steps 1 & 2. **3 or 4" 40wt galvanized pipe is recommended***. Cross measure for square. Allow concrete to cure (typically 1 day). Check posts for correct height before continuing.

Slide post adapters over steel posts (2 per post) and set a maximum of 12" from top & bottom of posts. Tighten set screws and tek screw to posts. **Double check post adapter alignment before fastening**

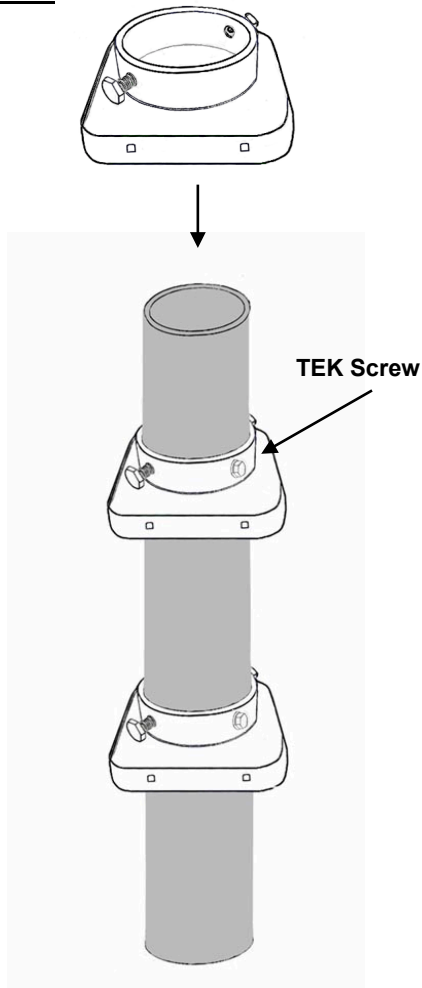

Rail adapters fit inside of steel posts. Align to fit layout. Drill pilot hole to secure rail adapters to steel posts (either through bolt, tek screw or shear pin). **Double check rail adapter alignment before fastening.**

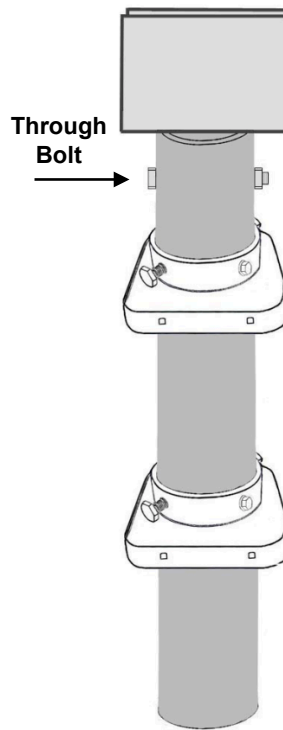
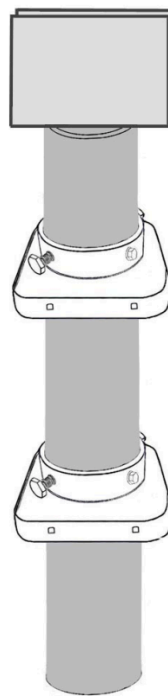

Sleeve PVC posts over steel posts, making sure holes align correctly.

***3" or 4" 40wt galvanized pipe can be found at most local fence companies.**

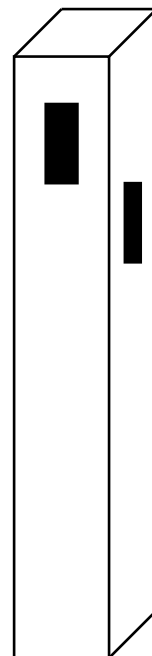

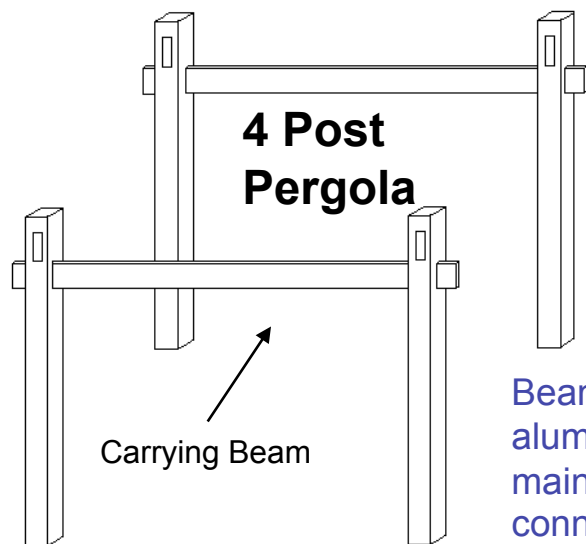

Slide filled 2x6 carrying beam through bottom holes, leaving equal amounts protruding (at least 3").

Beams must be filled with aluminum or steel to maintain metal to metal connection.

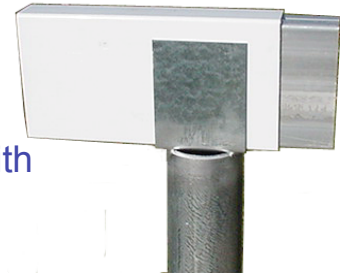

When placement of bottom beam is correct, place rail connector (A) inside post, over bottom carrying beam. It will be aligned so top cross beam will slide through (B). Slide filled cross beam through top holes, again leaving equal amounts protruding. If necessary, check for square. Ensure all beams extend equally beyond the posts before securing.

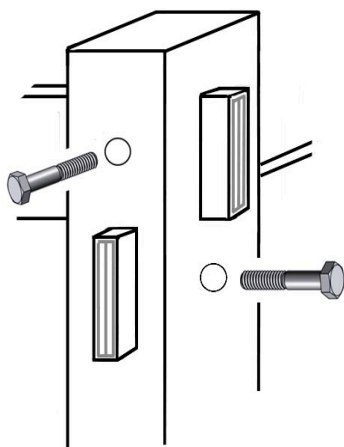
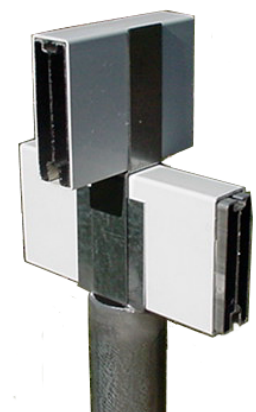
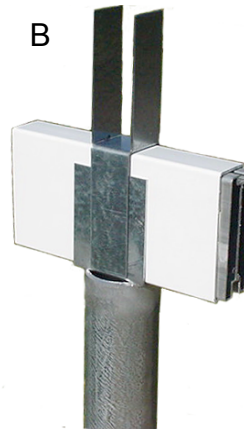
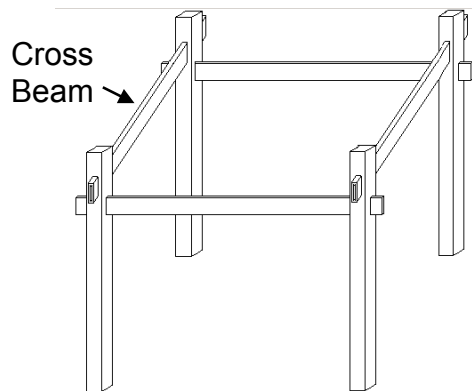

To secure the beams, drill 1" holes (1" spade bit recommended) corresponding to the area where the adapters will be secured (both sides of post). Drill 3/8" holes (min.) through rails, through bolt & tighten. Use stop nuts or lock washers with locktite to secure. Finish with 1" hole plugs for the PVC posts. The frame is now secure.

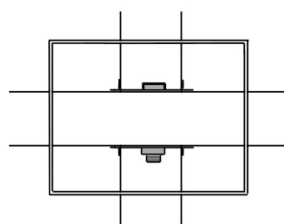

Determine placement for remaining cross beams. For a **four post pergola***, **all beams must be filled with aluminum or steel**. Measure bay (AB) and divide into equal increments. Place cross beams on carrying beams, fasten with 2" steel beam brackets

Determine placement for top cross ties using the same template. Cross ties may be 1 1/2" square or 2" x 3 1/2". Fasten to cross beams with steel beam brackets (1 1/2" or 2"). Begin with cross tie directly above carrying beam. The end ties can be cut to fit between posts or routed into posts.

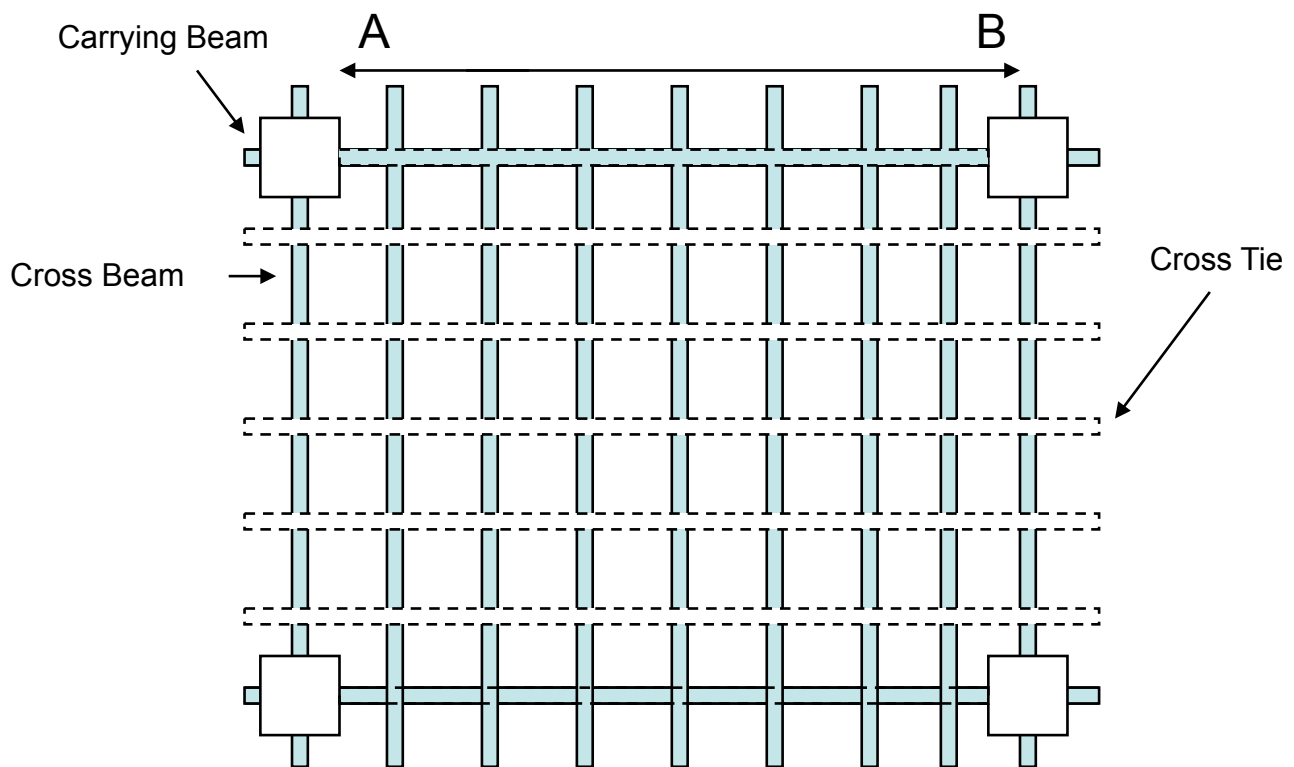

Attach all brackets. Install pergola caps and post caps. A small spot of glue on inside top and bottom of pergola cap is sufficient, gluing of post caps is optional.

***Four post pergola- all beams are filled, OPTION: carrying beams and end cross beams are filled, remaining cross beams may be ribbed (without added stiffeners) only if distance between carrying beams (AB) is 8' or less. If over 8', all beams must be filled.**

6 Post Pergola

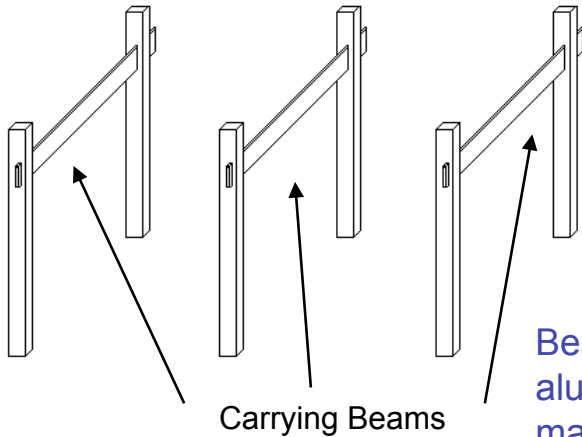

Slide filled 2x6 carrying beams through bottom holes, leaving equal amounts protruding. The middle carrying beam will eliminate the need for aluminum filled cross beams, as long as the span is 8' wide or less.

Beams must be filled with aluminum or steel to maintain metal to metal connection.

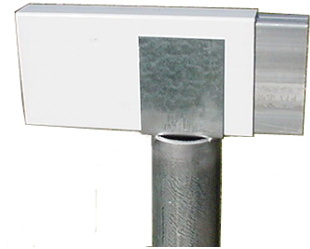

When placement of carrying beams are correct, place rail connector (A) inside post, over bottom carrying beam. It will be aligned so top cross beam will slide through (B). Slide filled cross beam through top holes, again leaving equal amounts protruding. If necessary, check for square.

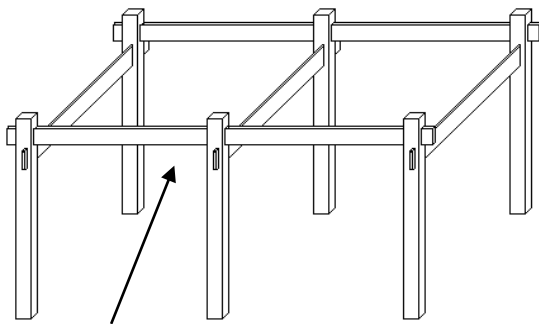

Cross Beam



A

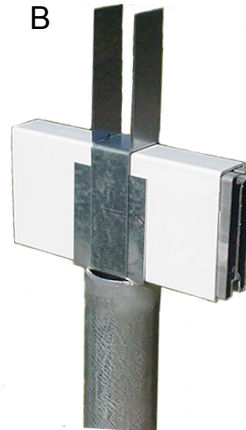

B

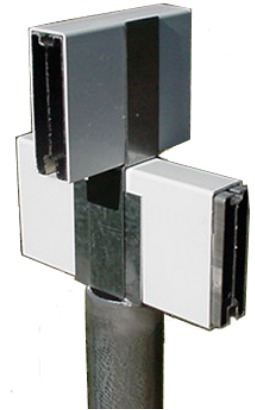

Inside Post View

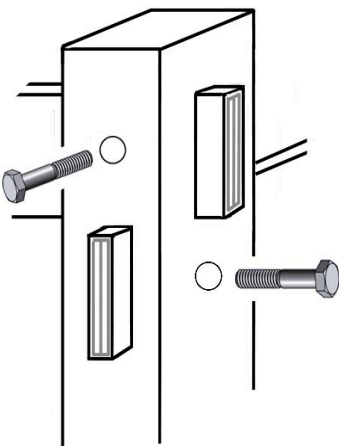

At this time, drill 1" holes corresponding to the area where the adapters will be secured. Drill 3/8" holes (min) through rails, through bolt & tighten. Use stop nuts or lock washers with locktite to secure. Finish with 1" hole plugs for the PVC posts. The frame is now secure.

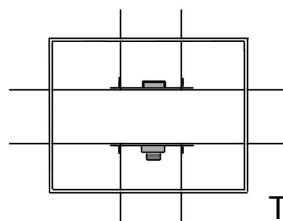

Top View

Determine placement for remaining cross beams. For a **six post pergola***, **end cross beams must be filled with aluminum or steel**. Measure bay (AB) and divide into equal increments. Place ribbed cross beams on carrying beams, fasten with 2" steel beam brackets. Determine placement for top cross ties using the same template. Cross ties may be 1 1/2" square or 2" x 3 1/2". Fasten to cross beams with steel beam brackets (1 1/2" or 2"). Begin with cross tie directly above carrying beam. The end ties can be cut to fit between posts or routed into posts.

Six Post Pergola with Ribbed Cross Beams

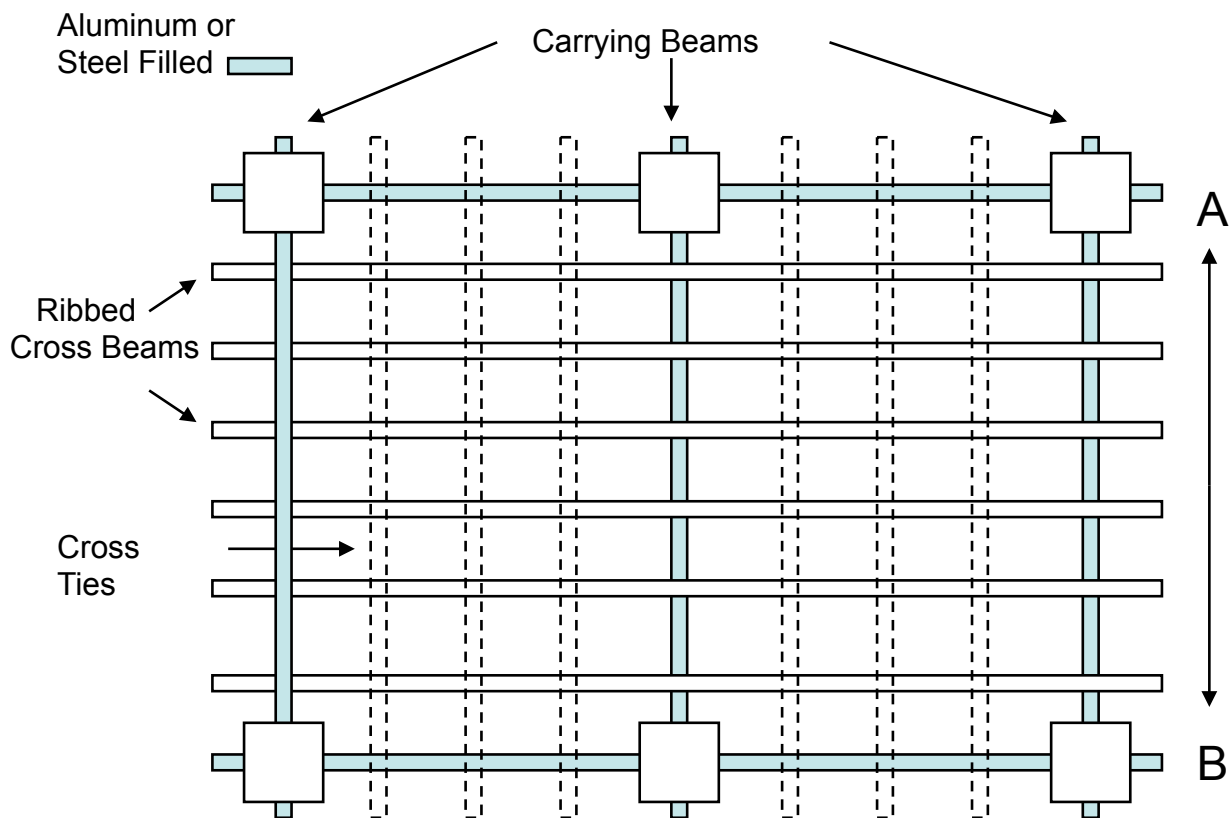

Attach all brackets. Install pergola caps and post caps. A small spot of glue on inside top and bottom of pergola cap is sufficient, gluing of post caps is optional.

***Six post pergola- end cross beams are filled, remaining cross beams may be ribbed (without stiffeners) only if distance between carrying beams (AB, BC) is 8' or less. If over 8', all beams must be filled).**